

Dimensions of Cap Nuts

Screw Thread			M4	M5	M6	M8	M10	M12	(M14)	M16	M18
P	Pitch	Coarse thread	0.7	0.8	1	1.25	1.5	1.75	2	2	2.5
		Fine thread	-	-	-	1	1.25	1.25	1.5	1.5	1.5
m2	Nominal Size		6.2	7.5	9.5	12.5	15.5	18.5	21	24	27
		max	6.45	7.75	9.75	12.8	15.8	18.8	21.3	24.4	27.4
		min	5.95	7.25	9.25	12.2	15.2	18.2	20.7	23.6	26.6
m	Nominal Size	max	3.2	4	5	6.5	8	10	11	13	15
		min	2.9	3.7	4.7	6.14	7.64	9.64	10.57	12.57	14.57
s	Nominal Size	max	7	8	10	13	17	19	22	24	27
		min	6.8	7.8	9.8	12.75	16.75	18.65	21.65	23.65	26.65
b	Nominal Size		3.2	4	5	6.5	8	10	11	13	15
A	min		5.6	6.6	8.5	11.5	14.5	16.5	19.5	21.5	23.5
t2	min		0.6	0.6	0.6	0.8	1	1.2	1.6	1.6	1.6
e	≈		8.1	9.2	11.5	15	19.6	21.9	25.4	27.7	31.2
dw	≈		6.8	7.8	9.8	12.5	16.5	18	21	23	26
R	≈		3	3.5	4.5	6.5	7.5	8	10	11	12
r	≈		0.5	0.5	0.5	0.5	0.5	1	1	1	1

NOTE: ALL DIMENSIONS ARE IN MM.

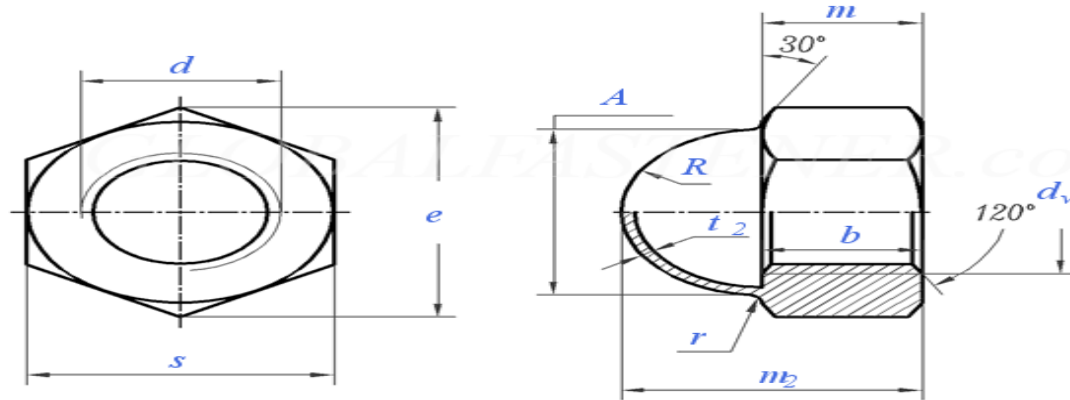

Dimensions of Cap Nuts

Screw Thread			M20	M22	M24	M27	M30	M33	M36	M39
d										
P	Pitch	Coarse thread	2.5	2.5	3	3	3.5	3.5	4	4
		Fine thread	1.5	1.5	2	2	2	2	3	3
m2	Nominal Size		29	32.5	35.5	41	45	49	54.5	59
	max		29.4	32.9	35.9	41.5	45.5	49.5	55	59.5
	min		28.6	32.1	35.1	40.5	44.5	48.5	54	58.5
m	max		16	18	19	22	24	26	29	31
	min		15.57	17.57	18.48	21.48	23.48	25.48	28.48	30.38
s	max		30	32	36	41	46	50	55	60
	min		29.65	31.6	35.6	40.6	45.6	49.6	54.55	59.55
b	Nominal Size		16	18	19	22	24	26	29	31
A	min		26.5	28.5	32.5	37.5	41.5	45.5	50.5	55.5
t2	min		1.6	2	2	2	2	2	2	2
e	≈		34.6	37	41.6	47.3	53.1	57.7	63.5	69.3
dw	≈		29	31	34	39	44	48	53	57
R	≈		13.5	14.5	16.5	19	21	23	25.5	28
r	≈		1	1	1	1.5	1.5	1.5	1.5	1.5