

Note: when the washer type is required, it shall be indicated in the order.

www.sunmach.net
info@sunmach.in
+91 20 24231345/46

Dimensions of Hex Nuts

Thread Size			M8	M10	M12	(M14)	M16	(M18)	M20	(M22)	M24	(M27)	M30
D													
P	Pitch	Fine thread-1	1	1	1.5	1.5	1.5	1.5	-2	1.5	2	2	2
		Fine thread-2	-	-1.25	-1.25	-	-	-	1.5	-	-	-	-
c	max		0.6	0.6	0.6	0.6	0.8	0.8	0.8	0.8	0.8	0.8	0.8
	min		0.15	0.15	0.15	0.15	0.2	0.2	0.2	0.2	0.2	0.2	0.2
da	max		8.75	10.8	13	15.1	17.3	19.5	21.6	23.7	25.9	29.1	32.4
	min		8	10	12	14	16	18	20	22	24	27	30
dw	min		11.63	14.63	16.63	19.64	22.49	24.85	27.7	31.35	33.25	38	42.75
e	min		14.38	17.77	20.03	23.36	26.75	29.56	32.95	37.29	39.55	45.2	50.85
m	max		6.8	8.4	10.8	12.8	14.8	15.8	18	19.4	21.5	23.8	25.6
	min		6.44	8.04	10.37	12.1	14.1	15.1	16.9	18.1	20.2	22.5	24.3
mw	min		5.15	6.43	8.3	9.68	11.28	12.08	13.52	14.48	16.16	18	19.44
s	max=nominal size		13	16	18	21	24	27	30	34	36	41	46
	min		12.73	15.73	17.73	20.67	23.67	26.16	29.16	33	35	40	45

NOTE: ALL DIMENSIONS ARE IN MM.

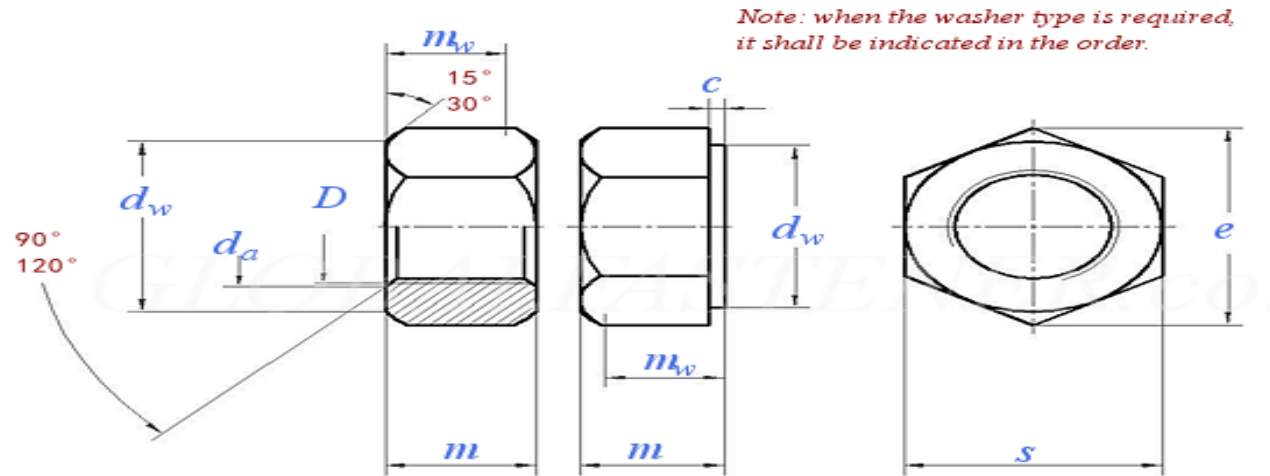

Dimensions of Hex Nuts

Thread Size D			M33	M36	(M39)	M42	(M45)	M48	(M52)	M56	M60	M64
P	Pitch	Fine thread-1	2	3	3	3	3	3	4	4	4	4
		Fine thread-2	-	-	-	-	-	-	-	-	-	-
c	max		0.8	0.8	1	1	1	1	1	1	1	1
	min		0.2	0.2	0.3	0.3	0.3	0.3	0.3	0.3	0.3	0.3
da	max		35.6	38.9	42.1	45.4	48.6	51.8	56.2	60.5	64.8	69.1
	min		33	36	39	42	45	48	52	56	60	64
dw	min		46.55	51.11	55.86	59.95	64.7	69.45	74.2	78.66	83.41	88.16
e	min		55.37	60.79	66.44	71.3	76.95	82.6	88.25	93.56	99.21	104.86
m	max		28.7	31	33.4	34	36	38	42	45	48	51
	min		27.4	29.4	31.8	32.4	34.4	36.4	40.4	43.4	46.4	49.1
mw	min		21.92	23.52	25.44	25.92	27.52	29.12	32.32	34.72	37.12	39.28
s	max=nominal size		50	55	60	65	70	75	80	85	90	95
	min		49	53.8	58.8	63.1	68.1	73.1	78.1	82.8	87.8	92.8

NOTE: ALL DIMENSIONS ARE IN MM.