

Dimensions of Socket Head Cap Screws

Thread Size d		M1.6	M2	M2.5	M3	M4	M5	M6	M8	M10	M12
P	pitch	0.35	0.4	0.45	0.5	0.7	0.8	1	1.25	1.5	1.75
b	thread length	15	16	17	18	20	22	24	28	32	36
dk	max (plain head)	3	3.8	4.5	5.5	7	8.5	10	13	16	18
	max (knurled heads*)	3.14	3.98	4.68	5.68	7.22	8.72	10.22	13.27	16.27	18.27
k	min	2.86	3.62	4.32	5.32	6.78	8.28	9.78	12.73	15.73	17.73
	max	1.6	2	2.5	3	4	5	6	8	10	12
s	Nominal Size	1.5	1.5	2	2.5	3	4	5	6	8	10
	max	1.58	1.58	2.08	2.58	3.08	4.095	5.14	6.14	8.175	10.175
	min	1.52	1.52	2.02	2.52	3.02	4.02	5.02	6.02	8.025	10.025
t	min	0.7	1	1.1	1.3	2	2.5	3	4	5	6
da	max	2	2.6	3.1	3.6	4.7	5.7	6.8	9.2	11.2	13.7
ds	max	1.6	2	2.5	3	4	5	6	8	10	12
	min	1.46	1.86	2.36	2.86	3.82	4.82	5.82	7.78	9.78	11.73
e	min	1.733	1.733	2.303	2.873	3.443	4.583	5.723	6.863	9.149	11.429
w	min	0.55	0.55	0.85	1.15	1.4	1.9	2.3	3.3	4	4.8

NOTE: ALL DIMENSIONS ARE IN MM.

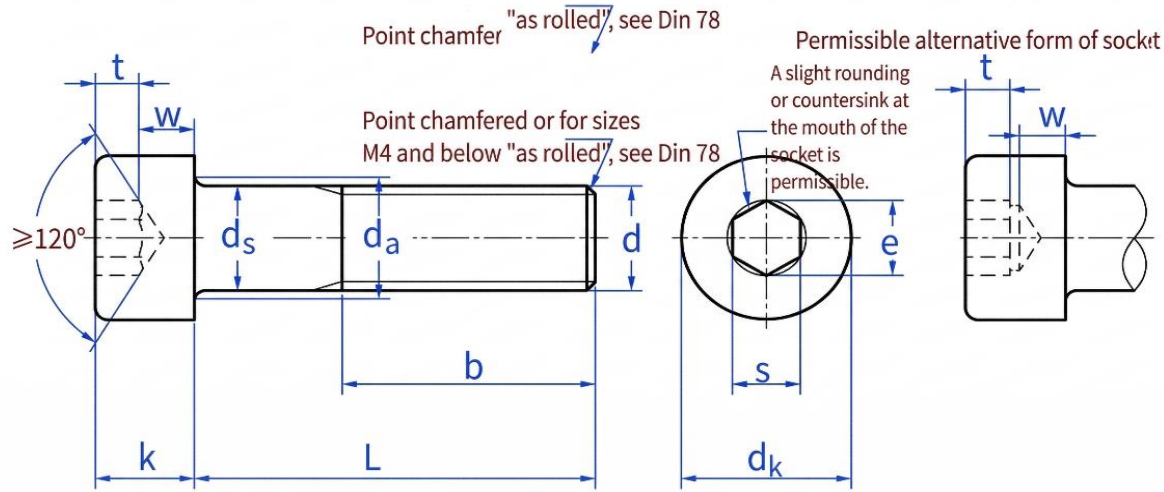

Dimensions of Socket Head Cap Screws

Thread Size d		(M14)	M16	M20	M24	M30	M36	M42	M48	M56	M64
P	pitch	2	2	2.5	3	3.5	4	4.5	5	5.5	6
b	thread length	40	44	52	60	72	84	96	108	124	140
dk	max (plain head)	21	24	30	36	45	54	63	72	84	96
	max (knurled heads*)	21.33	24.33	30.33	36.39	45.39	54.46	63.46	72.46	84.54	96.54
k	min	20.67	23.67	29.67	35.61	44.61	53.54	62.54	71.54	83.46	95.46
	max	14	16	20	24	30	36	42	48	56	64
s	Nominal Size	12	14	17	19	22	27	32	36	41	46
	max	12.212	14.212	17.23	19.275	22.275	27.275	32.33	36.33	41.33	46.33
t	min	12.032	14.032	17.05	19.065	22.065	27.065	32.08	36.08	41.08	46.08
	max	7	8	10	12	15.5	19	24	28	34	38
da	min	15.7	17.7	22.4	26.4	33.4	39.4	45.6	52.6	63	71
	max	14	16	20	24	30	36	42	48	56	64
ds	min	13.73	15.73	19.67	23.67	29.67	35.61	41.61	47.61	55.54	63.54
	max	13.716	15.996	19.437	21.734	25.154	30.854	36.571	41.131	46.831	52.531
e	min	5.8	6.8	8.6	10.4	13.1	15.3	16.3	17.5	19	22
w	min										